

- 1
- 2
- 3
- 4
- 5
- 6
- 7
- 8
- 9
- 10
- 11
- 12
- 13
- 14
- 15
- 16
- 17
- 18
- 19

**STANDARD EXECUTION**

Weldable AISI 316 turned stainless steel body.  
 Push-fit using AISI 316 stainless steel screws, cylindrical head with hexagonal socket.  
 Threaded pass-through hole ( $d1 = 20 \div 36$ ).  
 Threaded blind hole ( $d1 \geq 42$ ).

**FEATURES AND APPLICATIONS**

GN 707.2-A4 semi-split set collars can be used not only as end stops, but they can also be used for fixing other components, such as end limit switches.  
 No risk of damage to the surfaces of the shaft even when high clamping forces are necessary.  
 The clamping screws d3 may be replaced by clamping kit GN 311 (see page -).

**TECHNICAL DATA**

Assembly on h11 tolerance shafts.

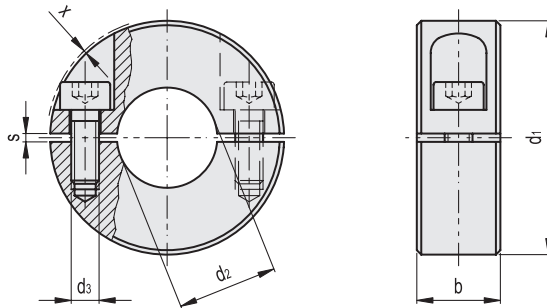

Code	Description	d1	d2 E8	d3	b±0.2	s	x*	⚖️
GN.45355	GN 707.2-20-B6-A4	20	B 6	M 3	9	1.6	1.2	18
GN.45356	GN 707.2-22-B8-A4	22	B 8	M 3	9	1.6	1	21
GN.45357	GN 707.2-26-B10-A4	26	B 10	M 4	11	1.6	1.6	35
GN.45358	GN 707.2-30-B12-A4	30	B 12	M 4	11	1.6	0.7	45
GN.45359	GN 707.2-32-B14-A4	32	B 14	M 4	11	1.6	0.7	50
GN.45360	GN 707.2-36-B15-A4	36	B 15	M 5	13	1.6	1.4	76
GN.45361	GN 707.2-36-B16-A4	36	B 16	M 5	13	1.6	1.4	75
GN.45362	GN 707.2-42-B18-A4	42	B 18	M 5	15	1.6	0.6	120
GN.45363	GN 707.2-42-B20-A4	42	B 20	M 5	15	1.6	0.6	110
GN.45364	GN 707.2-48-B22-A4	48	B 22	M 5	15	1.6	0	153
GN.45365	GN 707.2-48-B25-A4	48	B 25	M 5	15	1.6	0	138
GN.45366	GN 707.2-55-B28-A4	55	B 28	M 6	15	1.6	0.4	185
GN.45367	GN 707.2-55-B30-A4	55	B 30	M 6	15	1.6	0.4	170
GN.45368	GN 707.2-60-B32-A4	60	B 32	M 6	15	1.6	0.4	220
GN.45369	GN 707.2-60-B35-A4	60	B 35	M 6	15	1.6	0.4	180
GN.45370	GN 707.2-65-B40-A4	65	B 40	M 6	15	1.6	0.5	225

Standard machine parts

1 \* Max protrusion of the screw head.